

ICC-ES Evaluation Report

ESR-1504

Reissued June 1, 2009

This report is subject to re-examination in one year.

www.icc-es.org | (800) 423-6587 | (562) 699-0543

A Subsidiary of the International Code Council®

DIVISION: 07—THERMAL AND MOISTURE PROTECTION
Section: 07210—Building Insulation
Section: 07280—Water-Resistive Barrier

REPORT HOLDER:

ACH FOAM TECHNOLOGIES, LLC
5250 NORTH SHERMAN STREET
DENVER, COLORADO 80216
(303) 297-3844
www.achfoam.com

EVALUATION SUBJECT:**POLAR-R™ AND POLAR FOLD™ INSULATION BOARDS****1.0 EVALUATION SCOPE****Compliance with the following codes:**

- 2006 *International Building Code*® (IBC)
- 2006 *International Residential Code*® (IRC)

Properties evaluated:

- Durability
- Surface-burning characteristics
- Weather protection

2.0 USES**2.1 Polar-R Boards:**

Polar-R™ insulation boards are faced foam plastic boards used as nonstructural, thermal insulation, including for installation in wall cavities; as a component of classified roof assemblies or doors; or for installation on the exterior side of exterior walls of Type V-B construction or structures in accordance with the IRC. Polar-R™ boards may also be used as an alternative to the water-resistive barrier required by IBC Section 1404.2 and IRC Section R703.2.

2.2 Polar Fold™ Boards:

Polar Fold™ insulation boards are faced foam plastic boards used as nonstructural, thermal insulation, for installation in wall cavities; as a component of classified roof assemblies or doors; or for installation on the exterior side of walls of Type V-B construction in accordance with the IRC.

3.0 DESCRIPTION**3.1 Polar-R™ Boards:**

Polar-R™ boards consist of 1- to 4-inch-thick (25.4 to 102 mm) Foam-Control® expanded polystyrene (EPS) foam

plastic insulation boards (recognized in [ESR-1006](#)) laminated with a 1-mil (0.025 mm) opaque polypropylene film on the exterior face and a reflective metalized polypropylene film on the interior face. The Foam-Control® EPS boards may be Type I, II, VIII or IX in accordance with ASTM C 578, and have densities and thermal resistance values as shown in Table 1. The Foam-Control EPS foam boards have a flame spread index of 25 or less and a smoke-developed index of 450 or less. Polar-R™ boards are available in 2-foot-by-8-foot (610 mm by 2438 mm), 4-foot-by-8-foot (1219 mm by 2438 mm), and 4-foot-by-9-foot (1219 mm by 2743 mm) sizes. The boards have tongue-and-groove edges on the long sides (see Figure 1), and square edges on the short sides.

3.2 Polar-R™ Tape:

Polar-R™ Tape is used when Polar-R™ boards are used as an alternative water-resistive barrier as described in Section 4.2 to seal all vertical and horizontal joints. The tape consists of polyethylene backing with a rubber-based adhesive and has a nominal thickness of 9 mils (0.23 mm) and a nominal width of 2 inches (51 mm).

3.3 Polar Fold™ Boards:

Polar Fold™ consists of a ³/₈ inch and ¹/₂ inch thick (9.5 mm and 12.7 mm) Foam Control® expanded polystyrene (EPS) foam plastic insulation board (recognized in [ESR-1006](#)) laminated with a 1-mil (0.025 mm) opaque polypropylene film on the exterior face and a reflective metalized propylene film on the interior face. The Foam Control® EPS boards may be Type I, II, VIII, or IX in accordance with ASTM C 578 and have densities and thermal resistance values as shown in Table 1. The Foam Control® EPS foam boards have a flame spread index of 25 or less and a smoke developed of index of 450 or less. Polar Fold™ boards are available in a 4-foot-by-50-foot (1219 mm by 15.24 m) fan fold with a fold break every 2 feet (610 mm). The boards have square edges on all sides.

4.0 INSTALLATION**4.1 General:**

Installation of Polar-R™ and Polar Fold™ boards must comply with this report and the manufacturer's installation instructions. The interior of the building must be separated from the insulation boards with an approved thermal barrier as required by IBC Section 2603.4 or IRC Section R314.4. Where the probability of termite infestation is "very heavy," installation must comply with IBC Section 2603.8 or IRC Section R320.5. The Polar-R and Polar Fold™ boards have not been evaluated as a vapor retarder, so a vapor retarder must be installed when required by the applicable code.

The insulation boards applied to exterior faces of walls are limited to a maximum thickness of 1½ inches (38 mm), except insulation board thicknesses greater than 1½ inches (38 mm) may be permitted if such installation is recognized in a current ICC-ES evaluation report on a wall covering. The insulation boards must not be used as a nailing base for exterior siding materials. All nailing must be made through the insulation into the wall framing or structural sheathing as required by the siding manufacturer's installation instructions or the applicable code.

The attachment of finish materials over the insulation board must allow for a minimum 1-inch (25.4 mm) penetration of fasteners into wood framing. Sheathing or wall coverings must be structurally adequate to resist horizontal forces perpendicular to the wall. All walls must be braced in accordance with IBC Section 2308.9.3 or IRC Section R602.10.3.

Use of insulation boards as roof insulation is limited to installations recognized in a current ICC-ES evaluation report for the roof covering system.

4.2 Polar-R-Water-resistive Barrier

4.2.1 General: The boards must be installed in accordance with this report and the manufacturer's published installation instructions entitled "Polar-R™ Weather Resistive Barrier Detail Book," dated May 2008. This report and the manufacturer's published installation instruction must be available at the jobsite during installation.

One-inch-thick (25.4 mm) Polar-R™ boards may be used as an alternative to Type I felt complying with ASTM D 226 when installation is in accordance with this section. The boards must be installed horizontally with tongues faced upward, or installed vertically with no horizontal joints. Vertical joints must be backed by framing. Framing must be spaced a maximum of 24 inches (610 mm) on center. The Polar-R™ boards are attached with 1-inch-wide-crown (25.4 mm), No.16 gage corrosion-resistant staples spaced at 6 inches (152 mm) on center. The fasteners must have sufficient length to penetrate 1 inch (25.4 mm) into structural wood framing. Fastener crowns, joints between boards, and joints at corners made with the boards must be covered with Polar-R Tape centered over the joint. See Figure 2 for an illustration. The Polar-R board receiving the Polar-R Tape must be clean and dry.

A minimum 0.019-inch (0.48 mm) (No. 26 galvanized sheet gage) corrosion-resistant weep screed with a vertical attachment flange measuring a minimum of 3½ inches (89 mm) must be provided at the bottom of the wall. The installation of weep screeds must be in accordance with IBC Section 2512.1.2 or IRC Section R703.6.2.1.

4.2.2 Openings and Penetrations: Windows must be of the flanged type. Flashing of flange-type window penetrations when Polar-R boards are used as a water-resistive barrier is accomplished by installation of flashing tape complying with the ICC-ES Acceptance Criteria for Flashing Materials (AC148) covered under a current ICC-ES evaluation report. The flashing tape must completely cover the framing sill and extend a minimum of 8 inches (203 mm) up the sides of the opening and approximately 6 inches (152 mm) onto the face of the foam plastic board at the front of the window opening. The flashing tape must be flush with the inside edge of the framing members on the inside of the wall. See Figures 3-5 for illustrations. Flashing of doors and other framed openings must be as shown in Figure 6. See also Figure 7 for a typical flashing installation detail at wall/roof intersections.

Flashing of pipe penetrations must be accomplished by sealing around the pipe with silicone sealant complying with ASTM C 920, and flashing tape complying with AC148. Flashing of other penetrating items must be in accordance with the wall covering manufacturer's installation instructions.

5.0 CONDITIONS OF USE

The Polar-R™ and Polar Fold™ boards described in this report comply with, or are suitable alternatives to what is specified in, those codes listed in Section 1.0 of this report, subject to the following conditions:

- 5.1** Polar-R™ and Polar Fold™ boards must be installed in accordance with this report and the manufacturer's published installation instructions. In the event of a conflict between this report and the manufacturer's published installation instructions, this report governs.
- 5.2** Walls must be braced in accordance with the applicable code.
- 5.3** Polar-R™ and Polar Fold™ boards must not be used as a nailing base for exterior siding materials. All nailing must be made through the boards into the wall framing or structural sheathing as required by the siding manufacturer's installation instructions or the applicable code.
- 5.4** Polar-R™ and Polar Fold™ boards must be separated from the interior of the building with a thermal barrier complying with IBC Section 2603.4 or IRC Section R314.4.
- 5.5** Exterior walls must include an approved exterior wall covering, including a water-resistive barrier complying with IBC Section 1404.2 and IRC Section R703.2, as applicable. Polar-R™ boards may be used as the water-resistive barrier when installed in accordance with Section 4.2.
- 5.6** Polar-R™ boards may not be used as a water-resistive barrier with portland cement plaster where two layers of Grade D paper are required in accordance with IBC Section 2510.6 or IRC Section 703.6.3, except as described in a current ICC-ES evaluation report on an exterior wall covering.
- 5.7** Use of the foam plastic insulation in areas where the probability of termite infestation is "very heavy" must be in accordance with IBC Section 2603.8 or IRC Section R320.5.
- 5.8** For buildings in which the Polar-R™ boards described in this report are used as a water-resistive barrier, all plans must be accompanied by drawings, consistent with the illustrations in this report, that include the following:
 - a. Installation details at all openings, corners and insulation board terminations.
 - b. Location, configuration and method of sealing of joints between boards and at corners.
 - c. Typical cross section, showing all components of the wall.
 - d. Typical wall pipe and window penetration.
- 5.9** The foam plastic insulation used in manufacture of the Polar-R™ and Polar Fold™ boards is produced under [ESR-1006](#) and under a quality control program with inspections by Underwriters Laboratories (AA-668).
- 5.10** Polar-R™ and Polar Fold™ boards are manufactured by ACH Foam Technologies in Murray, Utah

6.0 EVIDENCE SUBMITTED

- 6.1 Data in accordance with the ICC-ES Acceptance Criteria for Foam Plastic Sheathing Panels Used as Weather-resistive Barriers (AC71), dated February 2003 (editorially revised June 2008).
- 6.2 Data in accordance with the ICC-ES Acceptance Criteria for Foam Plastic Installation (AC12), dated May 2008.

7.0 IDENTIFICATION

- 7.1 Polar R™ and Polar Fold™ boards are identified by a label bearing the following information: the company name (ACH Foam Technologies), product name,

plant identification code (U-2), EPS type, lot number, inspection agency name (Underwriters Laboratories Inc.), evaluation report number (ESR-1504) and labeling of the foam plastic in accordance with [ESR-1006](#).

- 7.2 Polar-R Tape is identified by a label bearing the company name (ACH Foam Technologies), the product name, dimensions and the evaluation report number (ESR-1504).

TABLE 1—DENSITIES AND R-VALUES FOR BOARDS

EPS TYPE	NOMINAL DENSITY (pcf)	MINIMUM DENSITY (pcf)	MINIMUM R-VALUE PER INCH OF THICKNESS AT 75°F (ft ² -hr-°F/Btu)
I	1.0	0.90	3.6
VIII	1.25	1.15	3.8
II	1.5	1.35	4.0
IX	2.0	1.80	4.2

For SI: 1pcf = 16.018 kg/m³, 1 inch = 25.4 mm.

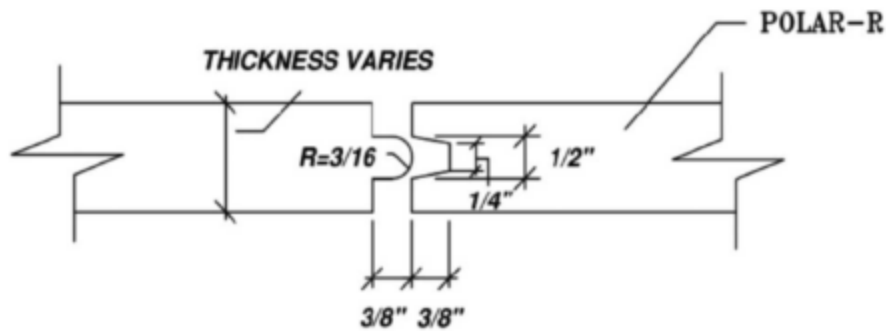

FIGURE 1—POLAR-R™ WEATHER RESISTIVE BARRIER EDGE DETAIL

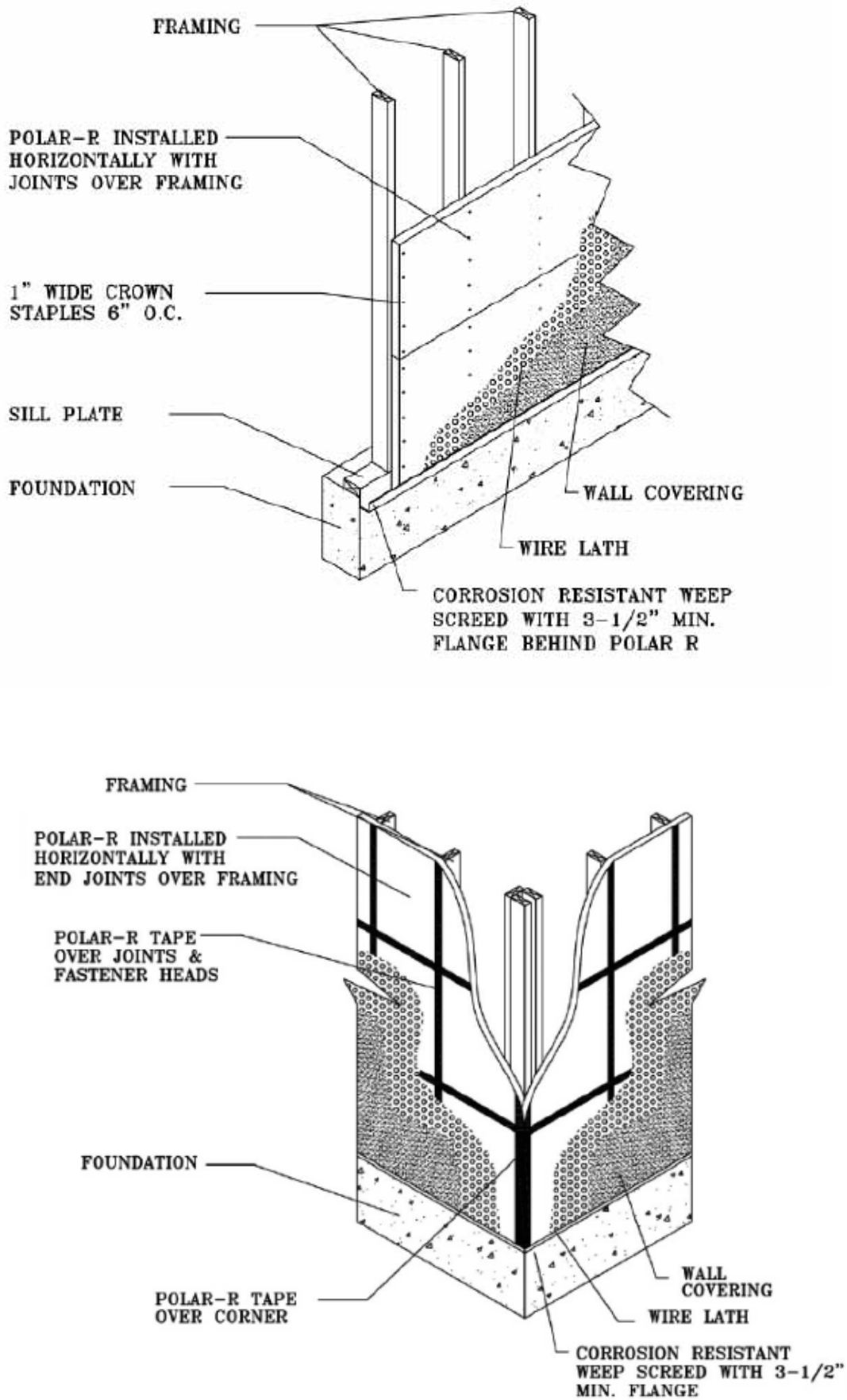

FIGURE 2—INSTALLATION DETAILS FOR POLAR-R™ AS A WATER-RESISTIVE BARRIER

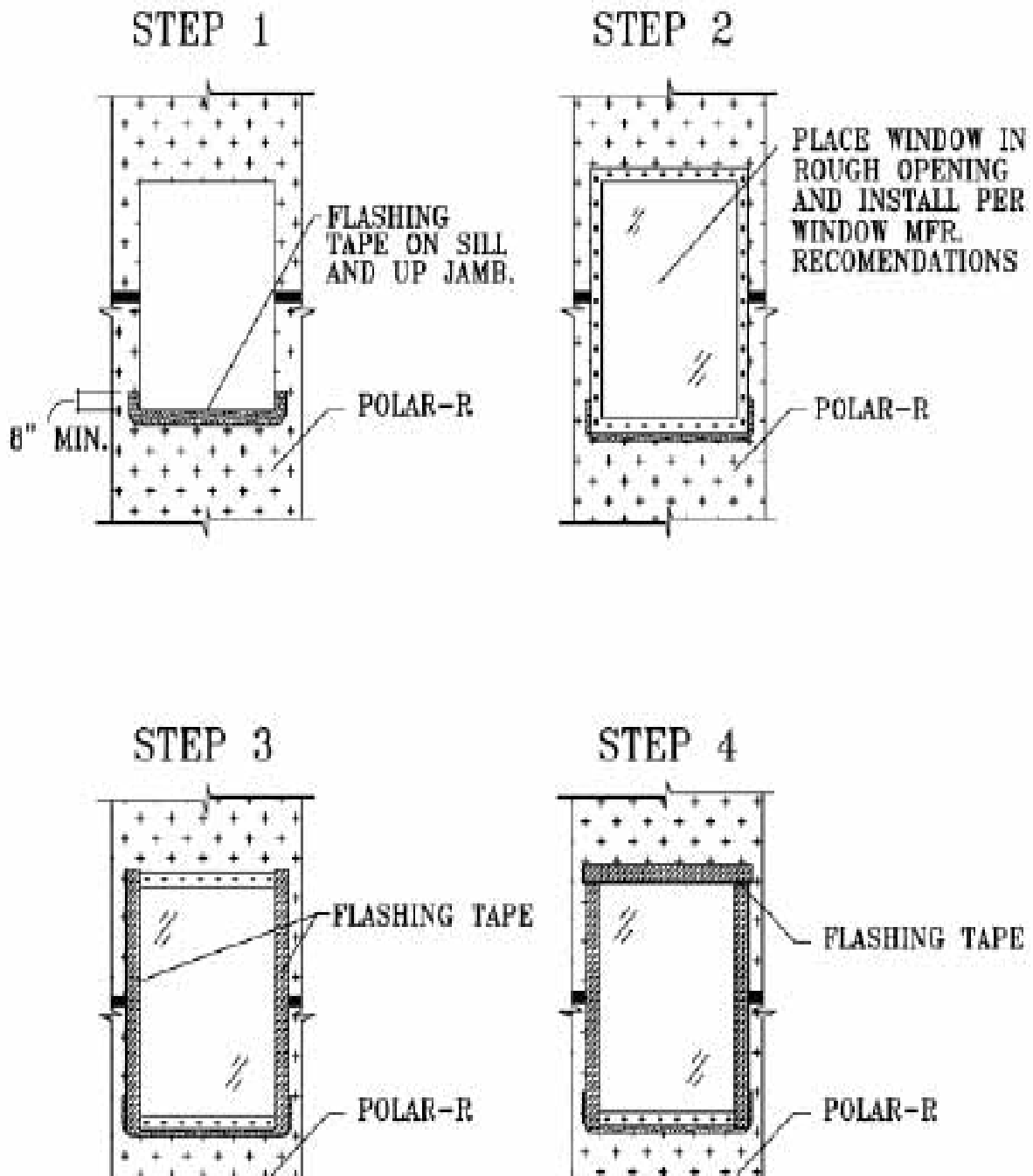

FIGURE 3—INSTALLATION DETAIL FOR POLAR-R™ AS A WATER-RESISTIVE BARRIER AROUND AN OPENING: WINDOW

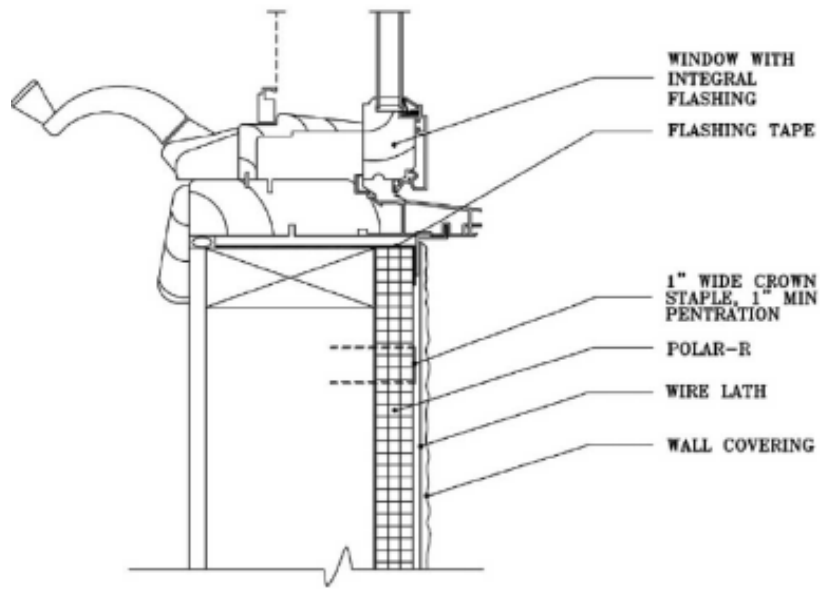

FIGURE 4—INSTALLATION DETAIL FOR POLAR-R™ AS A WATER-RESISTIVE BARRIER AROUND AN OPENING: WINDOW SILL

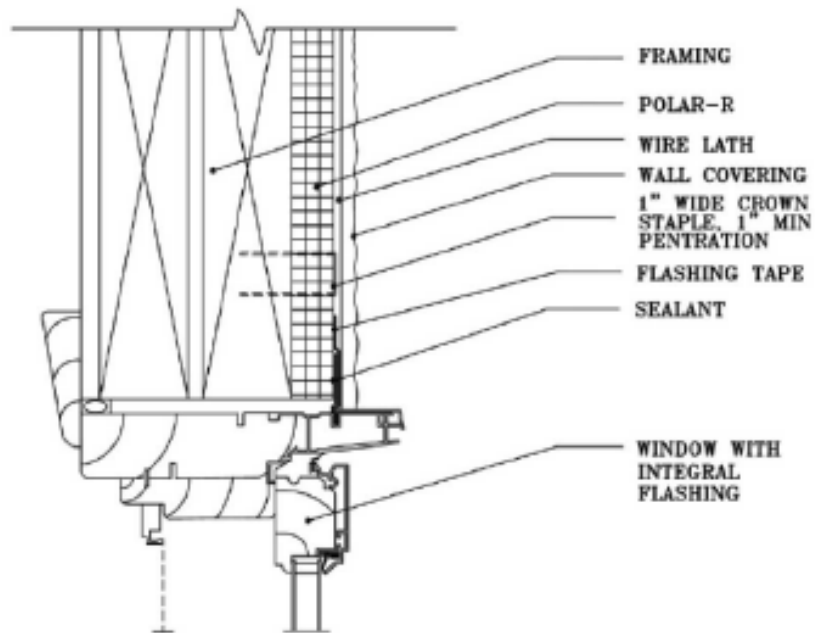

FIGURE 5—INSTALLATION DETAIL FOR POLAR-R™ AS A WATER-RESISTIVE BARRIER AROUND AN OPENING: WINDOW HEAD

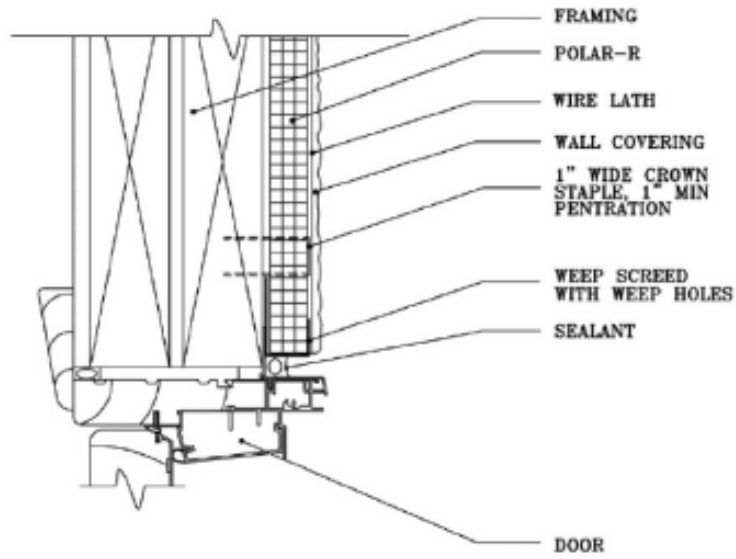

FIGURE 6—INSTALLATION DETAIL OF POLAR-R™ AS A WATER-RESISTIVE BARRIER AROUND AN OPENING: DOOR

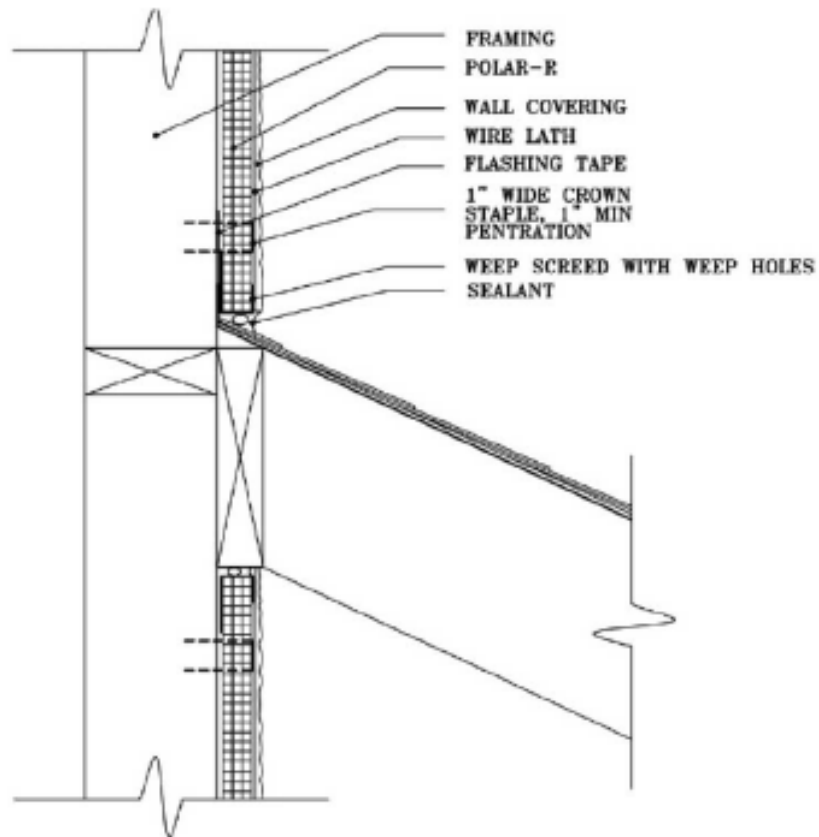

FIGURE 7—INSTALLATION OF POLAR-R AS A WATER-RESISTIVE BARRIER AT WALL/ROOF TERMINATION